

Lampiran 4 Datasheet Sensor MPX5100dp

NXP Semiconductors
Data Sheet: Technical Data

Document Number: MPX5100
Rev. 14, 12/2018



MPX5100, 0 to 100 kPa, Differential, Gauge, and Absolute, Integrated, Pressure Sensors

The MPX5100 series piezoresistive transducer is a state-of-the-art monolithic silicon pressure sensor designed for a wide range of applications, but particularly those employing a microcontroller or microprocessor with A/D inputs. This patented, single element transducer combines advanced micromachining techniques, thin-film metallization, and bipolar processing to provide an accurate, high-level, analog output signal that is proportional to the applied pressure.

Features

- 2.5% maximum error over 0 to 85 °C
- Ideally suited for microprocessor or microcontroller-based systems
- Patented silicon shear stress strain gauge
- Available in absolute, differential and gauge configuration
- Durable epoxy unibody element
- Easy-to-use chip carrier option

Typical applications

- Patient monitoring
- Process control
- Pump/motor control
- Pressure switching
- White goods

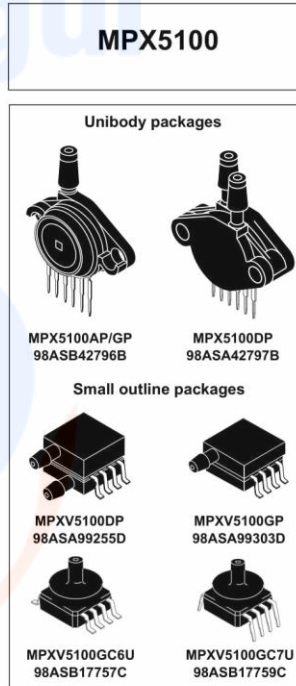

Ordering information									
Device name	Shipping	Package	# of Ports			Pressure type			Device marking
			None	Single	Dual	Gauge	Differential	Absolute	
Unibody Package (MPX5100 Series)									
MPX5100AP	Tray	98ASB42796B		•				•	MPX5100AP
MPX5100DP	Tray	98ASB42797B			•		•		MPX5100DP
MPX5100GP	Tray	98ASB42796B		•		•			MPX5100GP
Small Outline Package (MPXV5100 Series)									
MPXV5100DP	Tray	98ASA99255D			•		•		MPXV5100DP
MPXV5100GC6U	Rail	98ASB17757C		•		•			MPXV5100G
MPXV5100GC7U	Rail	98ASB17759C		•		•			MPXV5100G
MPXV5100GP	Tray	98ASA99303D		•		•			MPXV5100GP

NXP reserves the right to change the detail specifications as may be required to permit improvements in the design of its products.

© 2018 NXP Semiconductors, B.V.



Contents

1	General Description	3
1.1	MPX5100AP/DP/GP Block diagram	3
1.2	MPX5100AP/DP/GP Pinout (Unibody)	3
1.3	MPXV5100DP/GC6U/GC7U/GP block diagram	4
1.4	MPXV5100DP/GC6U/GC7U/GP pinout (small outline package)	4
2	Mechanical and Electrical Specifications	5
2.1	Maximum ratings	5
2.2	Operating characteristics	5
3	On-chip Temperature Compensation and Calibration	6
4	Package Information	9
4.1	Pressure (P1)/Gauge (P2) side identification table	9
4.2	Minimum recommended footprint for surface mounted applications	9
4.3	Package dimensions	9
5	Revision History	19

Related Documentation

The MPX5100 device features and operations are described in a variety of reference manuals, user guides, and application notes. To find the most-current versions of these documents:

1. Go to the NXP homepage at: <http://www.nxp.com/>
2. In the Keyword search box at the top of the page, enter the device number MPX5100.
3. In the Refine Your Result pane on the left, click on the Documentation link.

MPX5100

1 General Description

1.1 MPX5100AP/DP/GP Block diagram

Figure 1 shows a block diagram of the internal circuitry integrated on a pressure sensor chip in a unibody package.

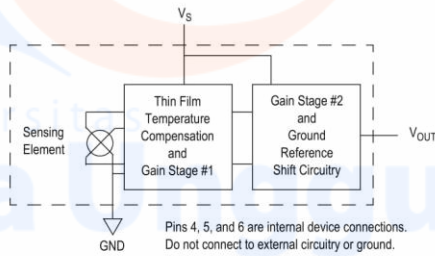

Figure 1. Integrated pressure sensor block diagram

1.2 MPX5100AP/DP/GP Pinout (Unibody)

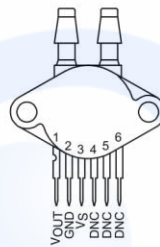

Figure 2. Device pinout (top view)

Table 1. Pin functions

Pin	Name	Function
1	V _{OUT}	Output voltage
2	GND	Ground
3	V _S	Voltage supply
4	DNC	Do not connect to external circuitry or ground.
5	DNC	Do not connect to external circuitry or ground.
6	DNC	Do not connect to external circuitry or ground.

MPX5100

Sensors
NXP Semiconductors, B.V.

3

1.3 MPXV5100DP/GC6U/GC7U/GP block diagram

Figure 1 shows a block diagram of the internal circuitry integrated on a pressure sensor chip in a small outline package.

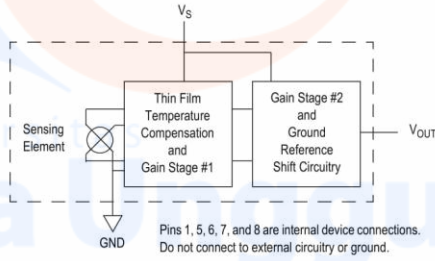

Figure 3. Integrated pressure sensor block diagram

1.4 MPXV5100DP/GC6U/GC7U/GP pinout (small outline package)

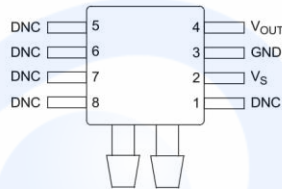

Figure 4. Device pinout (top view)

Table 2. Pin functions

Pin	Name	Function
1	DNC	Do not connect to external circuitry or ground.
2	V _S	Voltage supply
3	GND	Ground
4	V _{OUT}	Output voltage
5	DNC	Do not connect to external circuitry or ground.
6	DNC	Do not connect to external circuitry or ground.
7	DNC	Do not connect to external circuitry or ground.
8	DNC	Do not connect to external circuitry or ground.

MPX5100

4

Sensors
NXP Semiconductors, B.V.

2 Mechanical and Electrical Specifications

2.1 Maximum ratings

Table 3. Maximum ratings⁽¹⁾

Rating	Symbol	Value	Unit
Maximum pressure	P_{max}	400	kPa
Storage temperature	T_{stg}	-40 to +125	°C
Operating temperature	T_A	-40 to +125	°C

1. Exposure beyond the specified limits may cause permanent damage or degradation to the device.

2.2 Operating characteristics

Table 4. Operating characteristics ($V_S = 5$ Vdc, $T_A = 25$ °C.)

Characteristic	Symbol	Min	Typ	Max	Unit
Pressure range ⁽¹⁾ Gauge, differential: MPX5100G/MPXV5100G Absolute: MPX5100AP	P_{OP}	0 15	— —	100 115	kPa
Supply voltage ⁽²⁾	V_S	4.75	5.0	5.25	V _{DC}
Supply current	I_O	—	7.0	10	mAdc
Minimum pressure offset ⁽³⁾ , (0 to 85 °C) @ $V_S = 5.0$ V	V_{OFF}	0.088	0.20	0.313	V _{DC}
Full-scale output ⁽⁴⁾ , differential and absolute (0 to 85 °C) @ $V_S = 5.0$ V	V_{FSO}	4.587	4.700	4.813	V _{DC}
Full-scale Span ⁽⁵⁾ , differential and absolute (0 to 85 °C) @ $V_S = 5.0$ V	V_{FSS}	—	4.500	—	V _{DC}
Accuracy ⁽⁶⁾	—	—	—	±2.5	%V _{FSS}
Sensitivity	V/P	—	45	—	mV/kPa
Response time ⁽⁷⁾	t_R	—	1.0	—	ms
Output source current at full-scale output	I_{O+}	—	0.1	—	mAdc
Warm-up time ⁽⁸⁾	—	—	20	—	ms
Offset stability ⁽⁹⁾	—	—	±0.5	—	%V _{FSS}

1. 1.0 kPa (kiloPascal) equals 0.145 psi.

2. Device is ratiometric within this specified excitation range.

3. Offset (V_{OFF}) is defined as the output voltage at the minimum rated pressure.

4. Full-scale output (V_{FSO}) is defined as the output voltage at the maximum or full-rated pressure.

5. Full-scale span (V_{FSS}) is defined as the algebraic difference between the output voltage at full-rated pressure and the output voltage at the minimum rated pressure.

6. Accuracy (error budget) consists of the following:

Linearity: Output deviation from a straight line relationship with pressure over the specified pressure range.

Temperature hysteresis: Output deviation at any temperature within the operating temperature range, after the temperature is cycled to and from the minimum or maximum operating temperature points, with zero differential pressure applied.

Pressure hysteresis: Output deviation at any pressure within the specified range, when this pressure is cycled to and from minimum or maximum rated pressure at 25 °C.

TcSpan: Output deviation over the temperature range of 0 to 85 °C, relative to 25 °C.

TcOffset: Output deviation with minimum pressure applied over the temperature range of 0 to 85 °C, relative to 25 °C.

Variation from nominal: The variation from nominal values, for offset or full-scale span, as a percent of V_{FSS} at 25 °C.

7. Response time is defined as the time for the incremental change in the output to go from 10% to 90% of its final value when subjected to a specified step change in pressure.

8. Warm-up time is defined as the time required for the product to meet the specified output voltage after the pressure has been stabilized.

9. Offset stability is the product's output deviation when subjected to 1000 hours of pulsed pressure, temperature cycling with bias test.

MPX5100

Sensors
NXP Semiconductors, B.V.

5

3 On-chip Temperature Compensation and Calibration

Figure 5 shows the sensor output signal relative to pressure input. Typical, minimum, and maximum output curves are shown for operation over a temperature range of 0 to 85 °C using the decoupling circuit shown in Figure 7. The output will saturate outside of the specified pressure range.

Figure 6 illustrates both the Differential/Gauge and the Absolute Sensing Chip in the basic chip carrier. A fluorosilicone gel isolates the die surface and wire bonds from the environment, while allowing the pressure signal to be transmitted to the sensor diaphragm.

The MPX5100 series pressure sensor operating characteristics, and internal reliability and qualification tests are based on use of dry air as the pressure media. Media, other than dry air, may have adverse effects on sensor performance and long-term reliability. Contact the factory for information regarding media compatibility in your application.

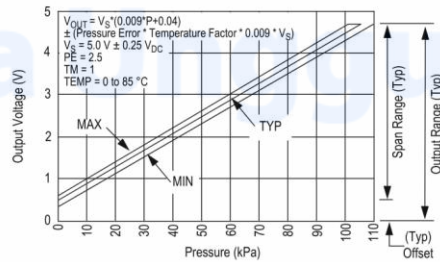

Figure 5. Output versus pressure differential

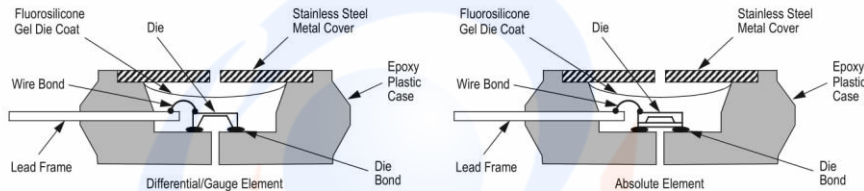

Figure 6. Cross-sectional diagrams (not-to-scale)

Figure 7 shows the recommended decoupling circuit for interfacing the output of the integrated sensor to the A/D input of a microprocessor or microcontroller. Proper decoupling of the power supply is recommended.

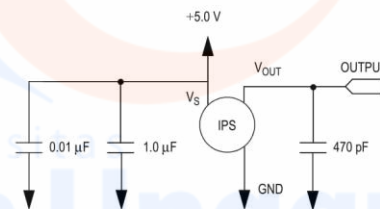

Figure 7. Recommended power supply decoupling and output filtering (For additional output filtering, please refer to application note AN1646.)

MPX5100

6

Sensors
NXP Semiconductors, B.V.

The following figures show the nominal transfer function, temperature and pressure error over the operating range for the MPX5100D, MPX5100G and MPXV5100G devices.

Nominal Transfer Value: $V_{OUT} = V_S (P \times 0.009 + 0.04)$
 $\pm (\text{Pressure Error} \times \text{Temp. Mult.} \times 0.009 \times V_S)$
 $V_S = 5.0 \text{ V} \pm 0.25 \text{ V}$

Figure 8. Transfer function (MPX5100D, MPX5100G, MPXV5100G)

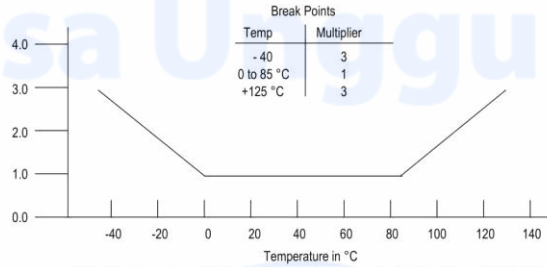

Note: The Temperature Multiplier is a linear response from 0 to -40 °C and from 85 to 125 °C.

Figure 9. Temperature error multiplier (MPX5100D, MPX5100G, MPXV5100G)

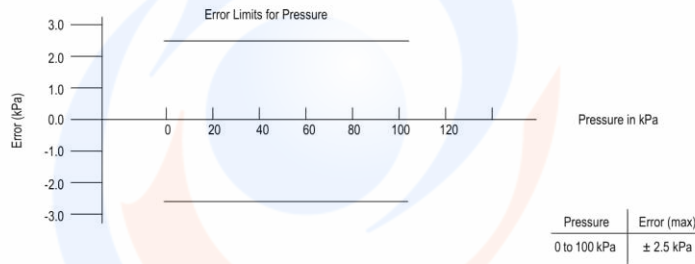
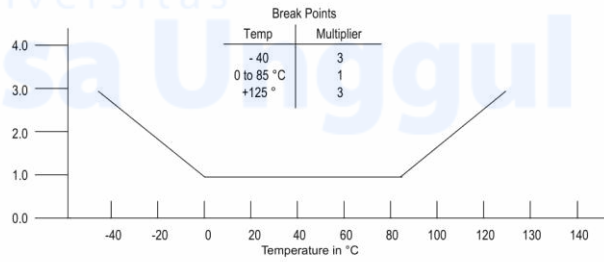

Figure 10. Pressure error band (MPX5100D, MPX5100G, MPXV5100G)

The following figures show the nominal transfer function, temperature and pressure error over the operating range for the MPX5100AP device.

Nominal Transfer Value: $V_{OUT} = V_S (P \times 0.009 - 0.095)$
 $\pm (\text{Pressure Error} \times \text{Temp. Mult.} \times 0.009 \times V_S)$
 $V_S = 5.0 \text{ V} \pm 0.25 \text{ V}$

Figure 11. Transfer function (MPX5100AP)



Note: The Temperature Multiplier is a linear response from 0 to -40 °C and from 85 to 125 °C.

Figure 12. Temperature error multiplier (MPX5100AP)

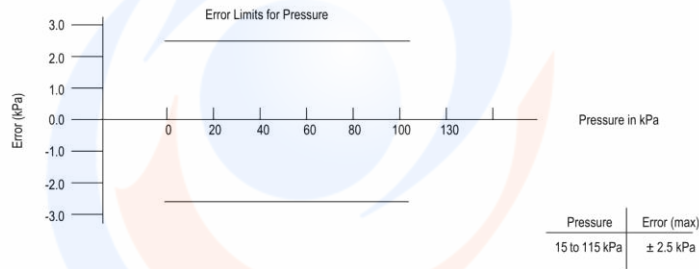

Figure 13. Pressure error band (MPX5100AP)

4 Package Information

4.1 Pressure (P1)/Gauge (P2) side identification table

NXP designates the two sides of the pressure sensor as the Pressure (P1) side and the Gauge (P2) side. The Pressure (P1) side is the side containing fluoro-silicone gel which protects the die from harsh media. The MPX pressure sensor is designed to operate with positive differential pressure applied, P1 > P2.

The Pressure (P1) side may be identified by using the table below.

Part number	Package	Pressure (P1) side identifier
MPX5100AP, MPX5100GP	98ASB42796B	Side with port attached
MPX5100DP	98ASB42797B	Side with part marking
MPXV5100DP	98ASA99255D	Side with part marking
MPXV5100GC6U	98ASB17757C	Side with port attached
MPXV5100GC7U	98ASB17759C	Side with port attached
MPXV5100GP	98ASA99303D	Side with port attached

4.2 Minimum recommended footprint for surface mounted applications

Surface mount board layout is a critical portion of the total design. The footprint for the surface mount packages must be the correct size to ensure proper solder connection interface between the board and the package. With the correct footprint, the packages will self align when subjected to a solder reflow process. It is always recommended to design boards with a solder mask layer to avoid bridging and shorting between solder

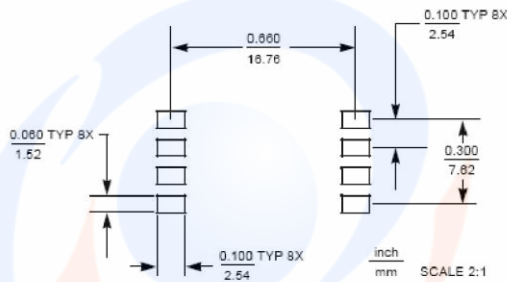
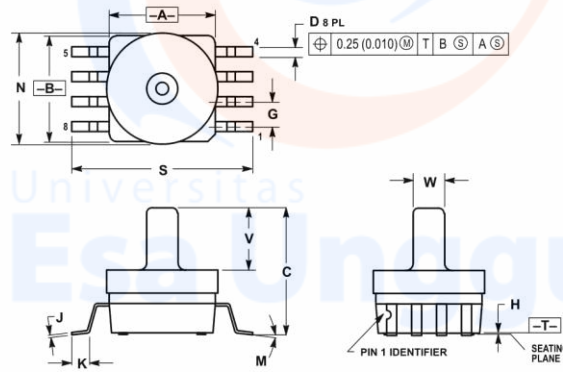

Figure 14. Small outline package footprint

4.3 Package dimensions

This drawing is located at http://cache.NXP.com/files/shared/doc/package_info/98ASB17757C.pdf.



- NOTES:
1. DIMENSIONING AND TOLERANCING PER ANSI Y14.5M, 1982.
 2. CONTROLLING DIMENSION: INCH.
 3. DIMENSION A AND B DO NOT INCLUDE MOLD PROTRUSION.
 4. MAXIMUM MOLD PROTRUSION 0.15 (0.006).
 5. ALL VERTICAL SURFACES 5° TYPICAL DRAFT.

DIM	INCHES		MILLIMETERS	
	MIN	MAX	MIN	MAX
A	0.415	0.425	10.54	10.79
B	0.415	0.425	10.54	10.79
C	0.500	0.520	12.70	13.21
D	0.038	0.042	0.96	1.07
G	0.100 BSC		2.54 BSC	
H	0.002	0.010	0.05	0.25
J	0.009	0.011	0.23	0.28
K	0.061	0.071	1.55	1.80
M	0°	7°	0°	7°
N	0.444	0.448	11.28	11.38
S	0.709	0.725	18.01	18.41
V	0.245	0.255	6.22	6.48
W	0.115	0.125	2.92	3.17

Case 98ASB17757C, 8-lead small outline package

MPX5100

10

Sensors
NXP Semiconductors, B.V.

This drawing is located at http://cache.NXP.com/files/shared/doc/package_info/98ASB17759C.pdf.

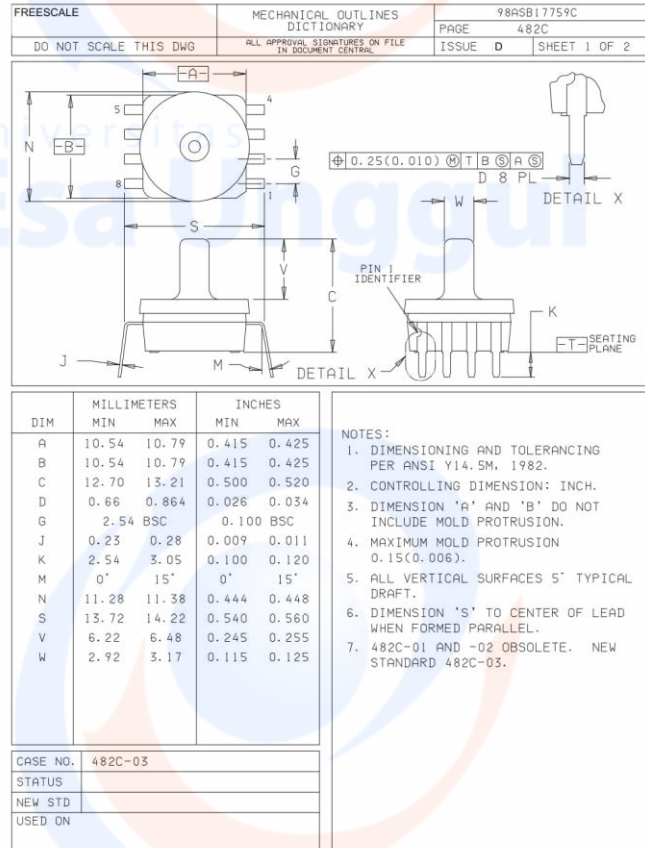

ELECTRONIC VERSIONS ARE UNCONTROLLED, EXCEPT WHEN ACCESSED DIRECTLY FROM WWC.
PRINTED VERSIONS ARE UNCONTROLLED, EXCEPT WHEN STAMPED "CONTROLLED COPY" IN RED.

Case 98ASB17759C, 8-lead small outline package

MPX5100

Sensors
NXP Semiconductors, B.V.

11

This drawing is located at http://cache.NXP.com/files/shared/doc/package_info/98ASB42796B.pdf.

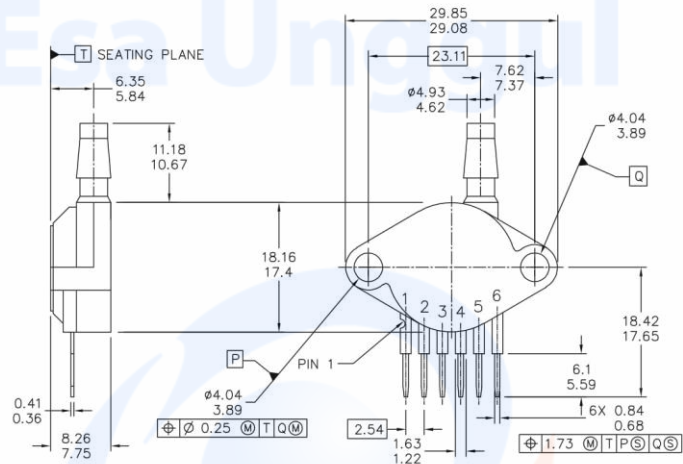

© FREESCALE SEMICONDUCTOR, INC. ALL RIGHTS RESERVED.	MECHANICAL OUTLINE	PRINT VERSION NOT TO SCALE
TITLE: SENSOR, 6 LEAD UNIBODY CELL, AP & GP 01ASB09087B	DOCUMENT NO: 98ASB42796B CASE NUMBER: 867B-04 STANDARD: NDN-JEDEC	REV: G 28 JUL 2005

Case 98ASB42796B, 6-lead unibody package

MPX5100

12

Sensors
NXP Semiconductors, B.V.

NOTES:

1. DIMENSIONS ARE IN MILLIMETERS.
2. DIMENSIONS AND TOLERANCES PER ASME Y14.5M-1994.
3. 867B-01 THRU -3 OBSOLETE, NEW STANDARD 867B-04.

© FREESCALE SEMICONDUCTOR, INC. ALL RIGHTS RESERVED.		MECHANICAL OUTLINE		PRINT VERSION NOT TO SCALE	
TITLE: SENSOR, 6 LEAD UNIBODY CELL, AP & GP 01ASB09087B		DOCUMENT NO: 98ASB42796B		REV: G	
		CASE NUMBER: 867B-04		28 JUL 2005	
		STANDARD: NON-JEDEC			

Case 98ASB42796B, 6-lead unibody package

MPX5100

This drawing is located at http://cache.NXP.com/files/shared/doc/package_info/98ASB42797B.pdf.

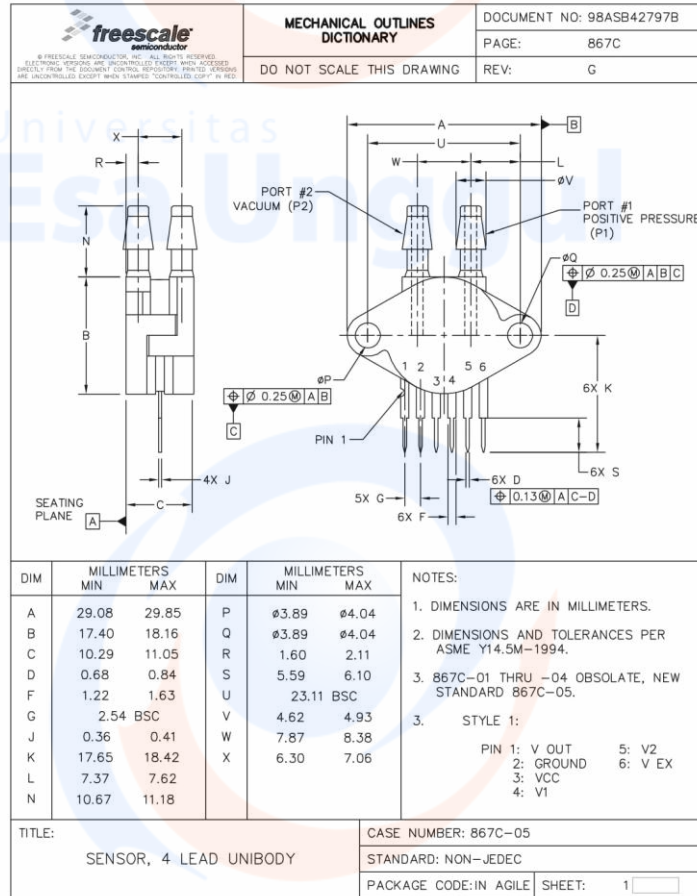

Case 98ASB42797B, 6-lead unibody package

MPX5100

14

Sensors
NXP Semiconductors, B.V.

This drawing is located at http://cache.NXP.com/files/shared/doc/package_info/98ASA99255D.pdf.

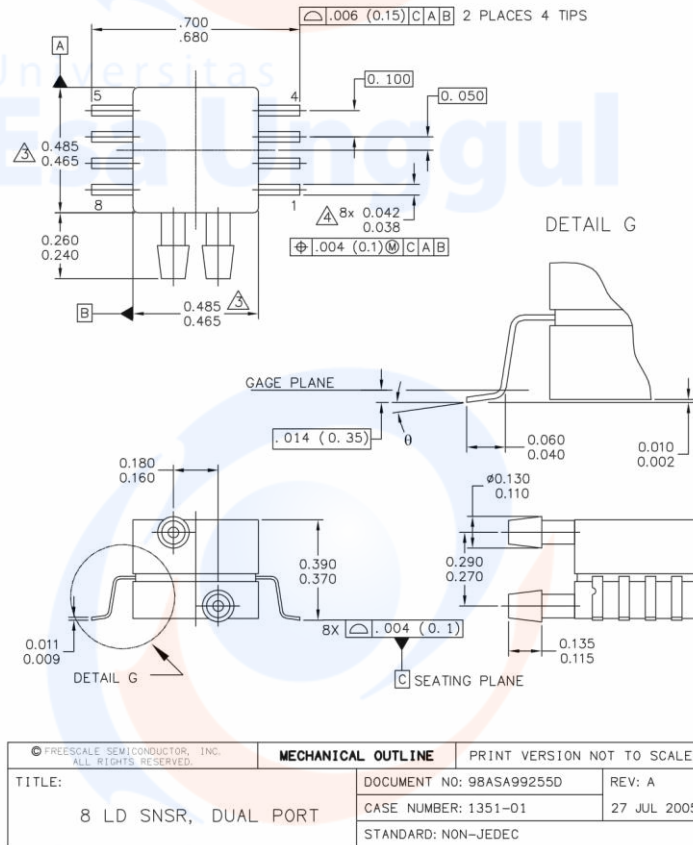

Case 98ASA99255D, 8-lead, dual port, small outline package

MPX5100

Sensors
NXP Semiconductors, B.V.

15

NOTES:

1. CONTROLLING DIMENSION: INCH
2. INTERPRET DIMENSIONS AND TOLERANCES PER ASME Y14.5M-1994.
3. DIMENSIONS DO NOT INCLUDE MOLD FLASH OR PROTRUSIONS. MOLD FLASH AND PROTRUSIONS SHALL NOT EXCEED .006 PER SIDE.
4. DIMENSION DOES NOT INCLUDE DAMBAR PROTRUSION. ALLOWABLE DAMBAR PROTRUSION SHALL BE .008 MAXIMUM.

© FREESCALE SEMICONDUCTOR, INC. ALL RIGHTS RESERVED.	MECHANICAL OUTLINE	PRINT VERSION NOT TO SCALE	
TITLE:	DOCUMENT NO: 98ASA99255D	REV: A	
8 LD SNSR, DUAL PORT	CASE NUMBER: 1351-01	27 JUL 2005	
	STANDARD: NON-JEDEC		

Case 98ASA99255D, 8-lead, dual port, small outline package

MPX5100

16

Sensors
NXP Semiconductors, B.V.

This drawing is located at http://cache.NXP.com/files/shared/doc/package_info/98ASA99303D.pdf.

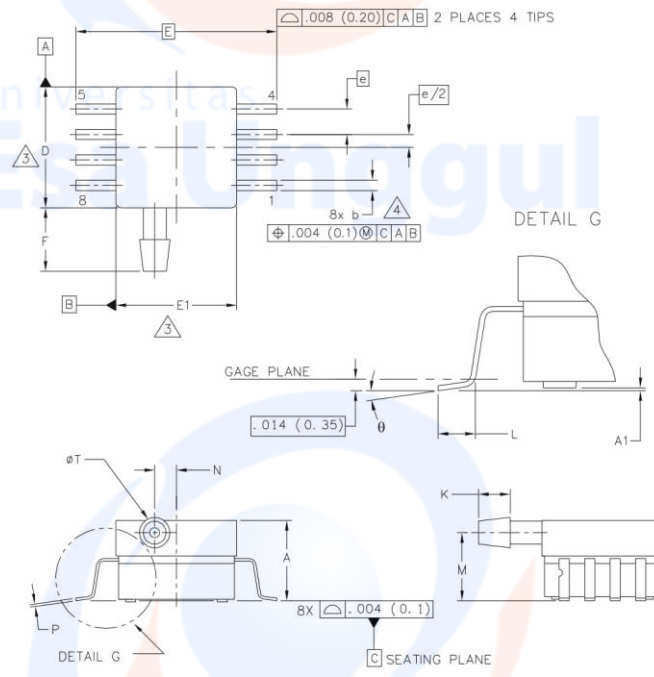

© FREESCALE SEMICONDUCTOR, INC. ALL RIGHTS RESERVED.	MECHANICAL OUTLINE	PRINT VERSION NOT TO SCALE
TITLE: 8 LD SOP, SIDE PORT	DOCUMENT NO: 98ASA99303D	REV: D
	CASE NUMBER: 1369-01	13 DEC 2010
	STANDARD: NON-JEDEC	

PAGE 1 OF 2

Case 98ASA99303D, 8-lead, side port, small outline package

MPX5100

Sensors
NXP Semiconductors, B.V.

17

- NOTES:
1. CONTROLLING DIMENSION: INCH
 2. INTERPRET DIMENSIONS AND TOLERANCES PER ASME Y14.5M-1994.
- ⚠ DIMENSIONS DO NOT INCLUDE MOLD FLASH OR PROTRUSIONS. MOLD FLASH AND PROTRUSIONS SHALL NOT EXCEED .006 (0.152) PER SIDE.
- ⚠ DIMENSION DOES NOT INCLUDE DAMBAR PROTRUSION. ALLOWABLE DAMBAR PROTRUSION SHALL BE .008 (0.203) MAXIMUM.

DIM	INCHES		MILLIMETERS		DIM	INCHES		MILLIMETERS	
	MIN	MAX	MIN	MAX		MIN	MAX	MIN	MAX
A	.300	.330	7.62	8.38	Ø	0"	7"	0"	7"
A1	.002	.010	0.05	0.25	-	---	---	---	---
b	.038	.042	0.96	1.07	-	---	---	---	---
D	.465	.485	11.81	12.32	-	---	---	---	---
E	.717 BSC		18.21 BSC		-	---	---	---	---
E1	.465	.485	11.81	12.32	-	---	---	---	---
e	.100 BSC		2.54 BSC		-	---	---	---	---
F	.245	.255	6.22	6.47	-	---	---	---	---
K	.120	.130	3.05	3.30	-	---	---	---	---
L	.061	.071	1.55	1.80	-	---	---	---	---
M	.270	.290	6.86	7.36	-	---	---	---	---
N	.080	.090	2.03	2.28	-	---	---	---	---
P	.009	.011	0.23	0.28	-	---	---	---	---
T	.115	.125	2.92	3.17	-	---	---	---	---

© FREESCALE SEMICONDUCTOR, INC. ALL RIGHTS RESERVED. MECHANICAL OUTLINE PRINT VERSION NOT TO SCALE

TITLE:	DOCUMENT NO: 98ASA99303D	REV: D
8 LD SOP, SIDE PORT	CASE NUMBER: 1369-01	13 DEC 2010
	STANDARD: NON-JEDEC	

Case 98ASA99303D, 8-lead, side port, small outline package

MPX5100

18

Sensors
NXP Semiconductors, B.V.

5 Revision History

Table 5. Revision history

Revision number	Revision date	Description of changes
14	12/2018	<ul style="list-style-type: none"> • Deleted obsolete part numbers MPX5100A and MPX5100D. • Changed format to new corporate format. • Added pinout for MPX5100AP/DP/GP in Figure 2. • Added pin functions for MPX5100AP/DP/GP as Table 1. • Added pinout for MPXV5100DP/GC6U/GC7U/GP as Figure 4. • Added pin functions for MPXV5100DP/GC6U/GC7U/GP as Table 2. • Moved section 5.1, Package dimensions to Section 4.3. • Deleted section 5, duplicate Package Information section. • Added revision history as Table 5.

How to Reach Us:

Home Page:
NXP.com

Web Support:
NXP.com/support

Information in this document is provided solely to enable system and software implementers to use NXP products. There are no expressed or implied copyright licenses granted hereunder to design or fabricate any integrated circuits based on the information in this document. NXP reserves the right to make changes without further notice to any products herein.

NXP makes no warranty, representation, or guarantee regarding the suitability of its products for any particular purpose, nor does NXP assume any liability arising out of the application or use of any product or circuit, and specifically disclaims any and all liability, including without limitation, consequential or incidental damages. "Typical" parameters that may be provided in NXP data sheets and/or specifications can and do vary in different applications, and actual performance may vary over time. All operating parameters, including "typicals," must be validated for each customer application by the customer's technical experts. NXP does not convey any license under its patent rights nor the rights of others. NXP sells products pursuant to standard terms and conditions of sale, which can be found at the following address:

NXP.com/salestermsandconditions.

NXP and the NXP logo are trademarks of NXP Semiconductors, B.V. All other product or service names are the property of their respective owners.

© NXP Semiconductors, B.V., Inc., 2018. All Rights reserved.

Document Number: MPX5100
Rev. 14
12/2018

